

Project "Reinventing the Wheel - Agile Integrated Technological and Green Transition of the STARCO Beli Manastir into a Leading Regional Lean and Green Steel Forming Factory" received a grant from the Norwegian financial mechanism within the Business Development and Innovation Croatia Programme 2014 - 2021.

In accordance with the funding regulation, all documents on the procurement process and the award procedure within the framework of the project "Reinventing the Wheel - Agile Integrated Technological and Green Transition of the STARCO Beli Manastir into a Leading Regional Lean and Green Steel Forming Factory" can be found on the Project Promotors web site. Based on the Procurement procedure for Entities not subject to Public Procurement Act, STARCO Beli Manastir d.o.o. herewith publishes:

## INVITATION TO TENDER FOR ACQUISITION OF WHEEL HANGERS FOR INTEGRATION INTO EXISTING PAINT LINE

Contract number: 2023/364026

Procurement number: 2023/364026 – P2

### 1. GENERAL DATA

The project "Reinventing the Wheel - Agile Integrated Technological and Green Transition of the STARCO Beli Manastir into a Leading Regional Lean and Green Steel Forming Factory" is supported by the Norway Grants as part of the Programme on Business Development and Innovation operated by Innovation Norway. To achieve the aim of the project – procurement of necessary equipment, there will be several tender procedures held in accordance with Procurement procedure for Entities not subject to Public Procurement Act by the publication of the procurement notice – INVITATION TO TENDER, and it will be available at the Project Promotors web page: <https://starco.com/tender>

#### 1.1 Data on Contracting Project Promotor

PROJECT PROMOTOR: STARCO Beli Manastir d.o.o.

ADDRESS: Osječka 1a, 31300 Beli Manastir, Croatia

PERSONAL ID (OIB): 80334990436

PHONE NUMBER: +385 31 710001

EMAIL: info.hr@starco.com

Contact Person

NAME: Dejan Adler, Supply Chain Manager

PHONE: +385 91 3710113

EMAIL: dejan.adler@starco.com

## **2. DATA ON THE SUBJECT MATTER OF PROCUREMENT**

### **2.1 Description of the subject matter of procurement**

Two main wheel types manufactured are “pressed” and “spun”. Pressed wheels are made by joining 2 formed halves into one and welding them together, whereas spun wheels are made by forming the cylinder into a rim, followed by inserting a disc inside and welding the two pieces together.

Wheels are carried on hangers through the chemical pre-treatment and painting segments of production before finally reaching the curing ovens. Conveyor is used to move the hangers forward to complete a full cycle and does so in a continuous (non-stop) motion.

While moving through the chemical pre-treatment, wheels and hangers are exposed to various degreasing and enhancing chemicals.

### **2.2 Technical specifications of the subject matter of procurement**

Technical specifications of the subject matter of procurement are contained bellow; product types, standards or other features mentioned in the specification are references, but “equivalent” features from the supplier are also accepted.

Evidence of equivalence must be provided by the bidder in the context of the tender using suitable means, such as submitted technical specifications, technical data, and the like.

Technical data serves as a basis for assessing whether the subject offered has the specified properties.

When designing for this specific tender, it’s allowed to use the internal company designs and ideas as shown below.

### **2.3. Specifications**

- Conveyor speed varies according to different wheel sizes and is shown below:
  - 2,5 m/min for wheel sizes under 22,5”
  - 2,0 m/min for wheel sizes of 22,5” and above
- Wheel weight ranges from 2 kg to 225 kg and conveyor has turns and inclines up to 45° in different locations, therefore hangers must ensure safe wheel carriage
- configuration has to be as lightweight as possible to ensure lower heat losses through the paint curing process
- Wheels must be carried by hangers in horizontal (natural rolling) position (up to 3° incline from horizontal is allowed)

\* This enables automatic powder coating guns to coat the wheels in a way that satisfies quality standards

- Hangers also serve as a grounded connection for wheels due to automatic powder guns ionizing the powder which then gets deposited on the wheel
- Each wheel has a bead seat area where the tire is in contact with the wheel - this area must not be touched by the hangers to ensure correct painting.

\* This prevents corrosion and air leaks after mounting tires

- Resistance to non-thinning chemicals whose pH value varies from 13 to 4
- Resistance to varying heat cycles from 0 °C to 250 °C
- Maximum hanger height allowed is 2000mm and maximum height of wheels loaded on hanger is 1800mm to enable complete submerging into enhancing chemicals pool
- Quantity of hangers depends on quantity of wheels carried by a single hanger with aim to maximize the painting output per square meter

- 375 units - carrying pressed wheels - typically 10 per hanger
  - diameter 6" - 9"
  - width 2,5" - 7"
  - 1kg - 4kg per wheel
- 375 units - carrying pressed wheels - typically 4-8 per hanger
  - diameter 10" - 12"
  - width 3,5" - 7"
  - 3kg - 6kg per wheel
- 375 units - carrying the spun wheels - typically 10 per hanger
  - diameter 8" - 10"
  - width 3,5" - 9,5"
  - 3kg - 7kg per wheel
- 300 units - carrying the spun wheels - typically 3 per hanger
  - diameter 12" - 16,5"
  - width 6" - 13"
  - 7kg - 28kg per wheel
- 250 units - carrying the spun wheels - typically 2 per hanger
  - diameter 17" - 20"
  - width 6,75" - 16"
  - 23kg - 50kg per wheel
- 250 units - carrying the spun wheels - 1 per hanger
  - diameter 22,5" - 30,5"
  - width 11" - 28"
  - 50kg - 225kg per wheel

\* Different group configuration is allowed if all sizes are taken care of by the use of same hanger with a number of interchangeable fixtures

- A mathematical fatigue analysis and simulation have to be created for every type of hanger, with the addition of a load certificate

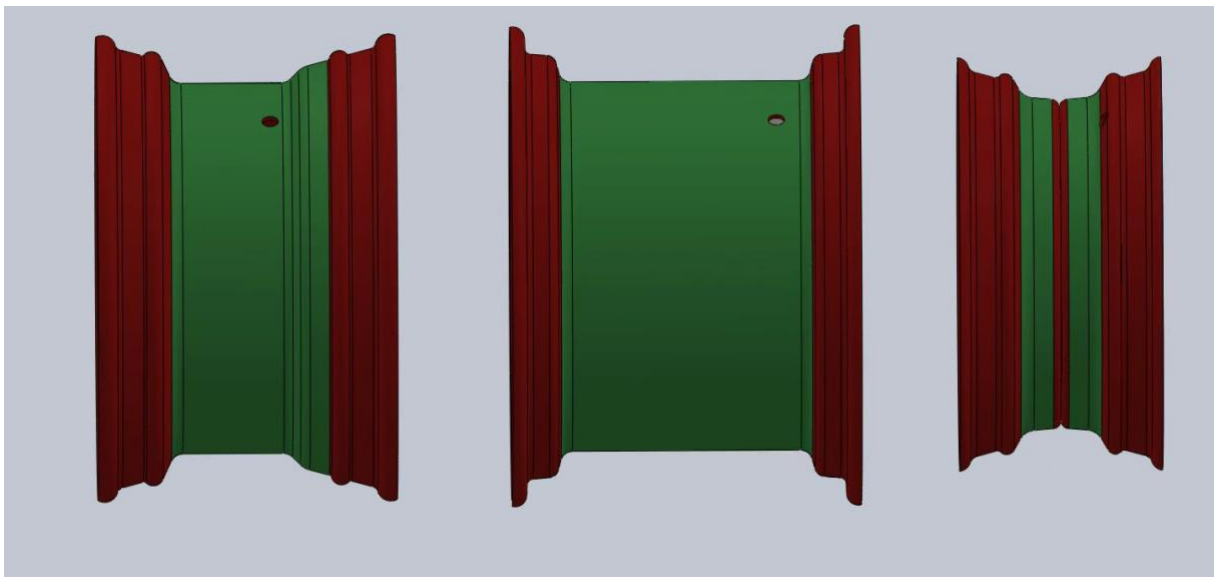

Figure 1: Allowed contact area between the hanger and the wheel, 2 spun wheels, 1 pressed wheel

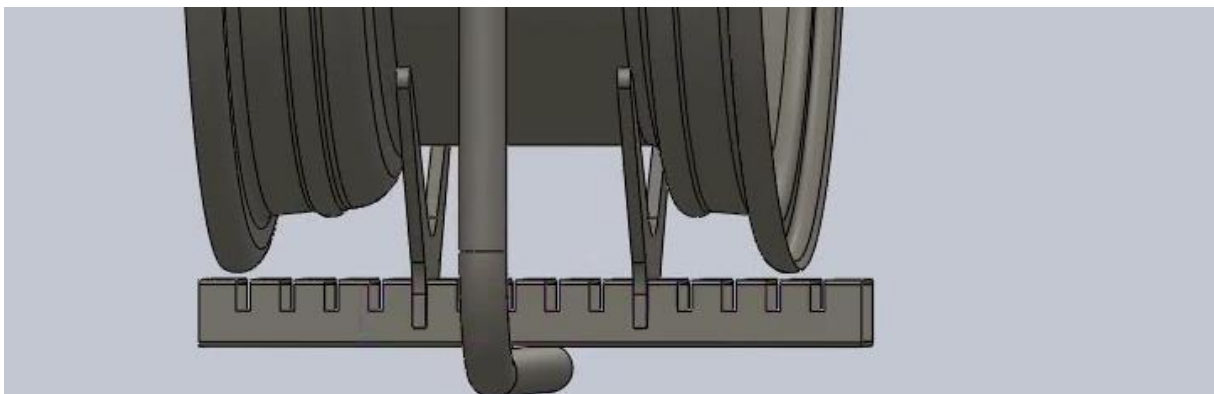

Figure 2: V-shaped cut-out

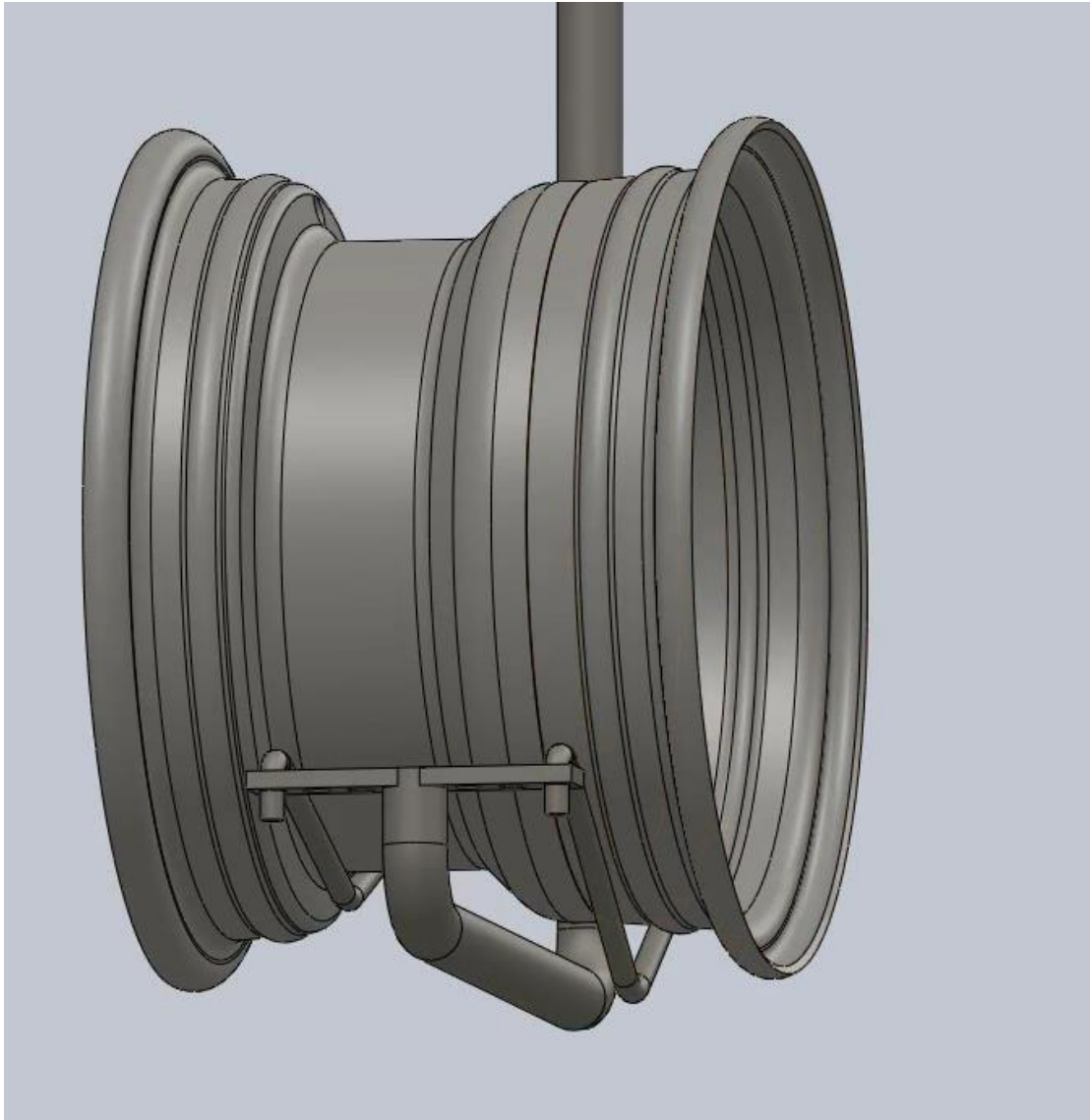

Figure 3: Example of 8" spun (1 piece) wheel

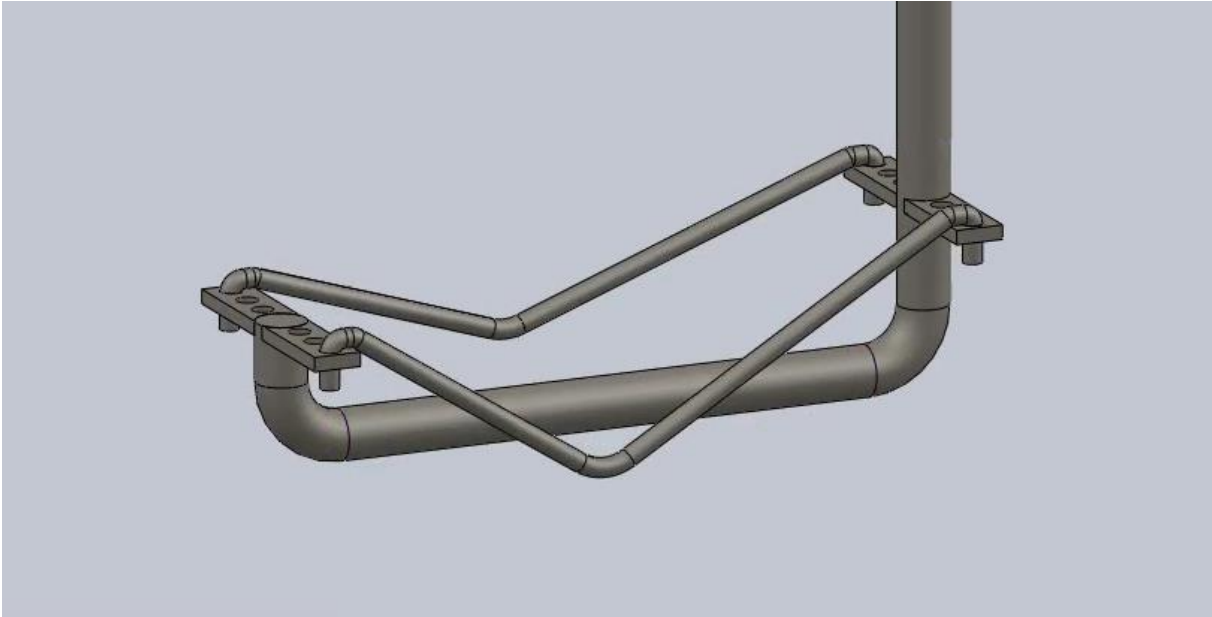

Figure 4: Set of fixtures to allow for uneven well area of the wheel

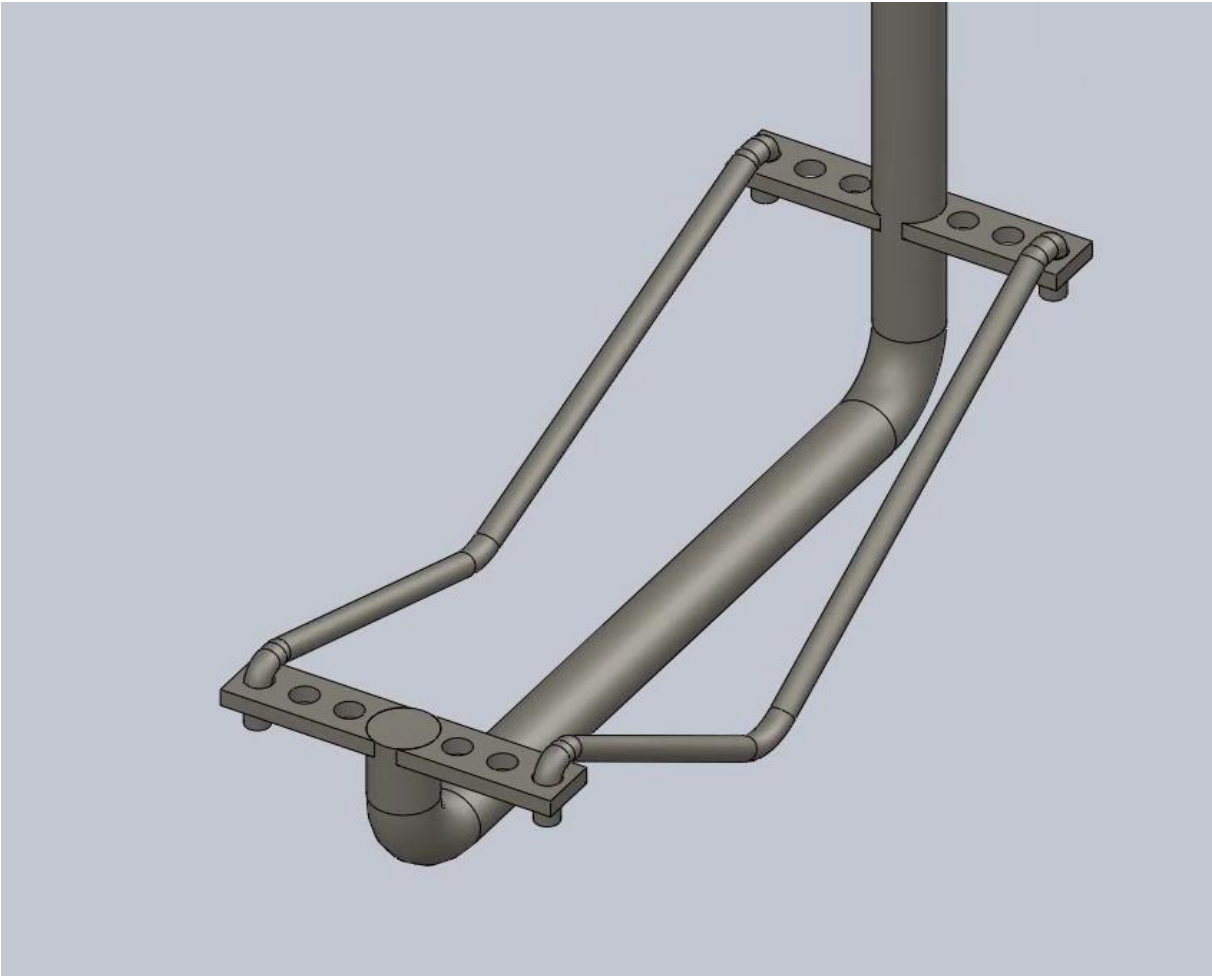

Figure 5: Top view of the figure 4

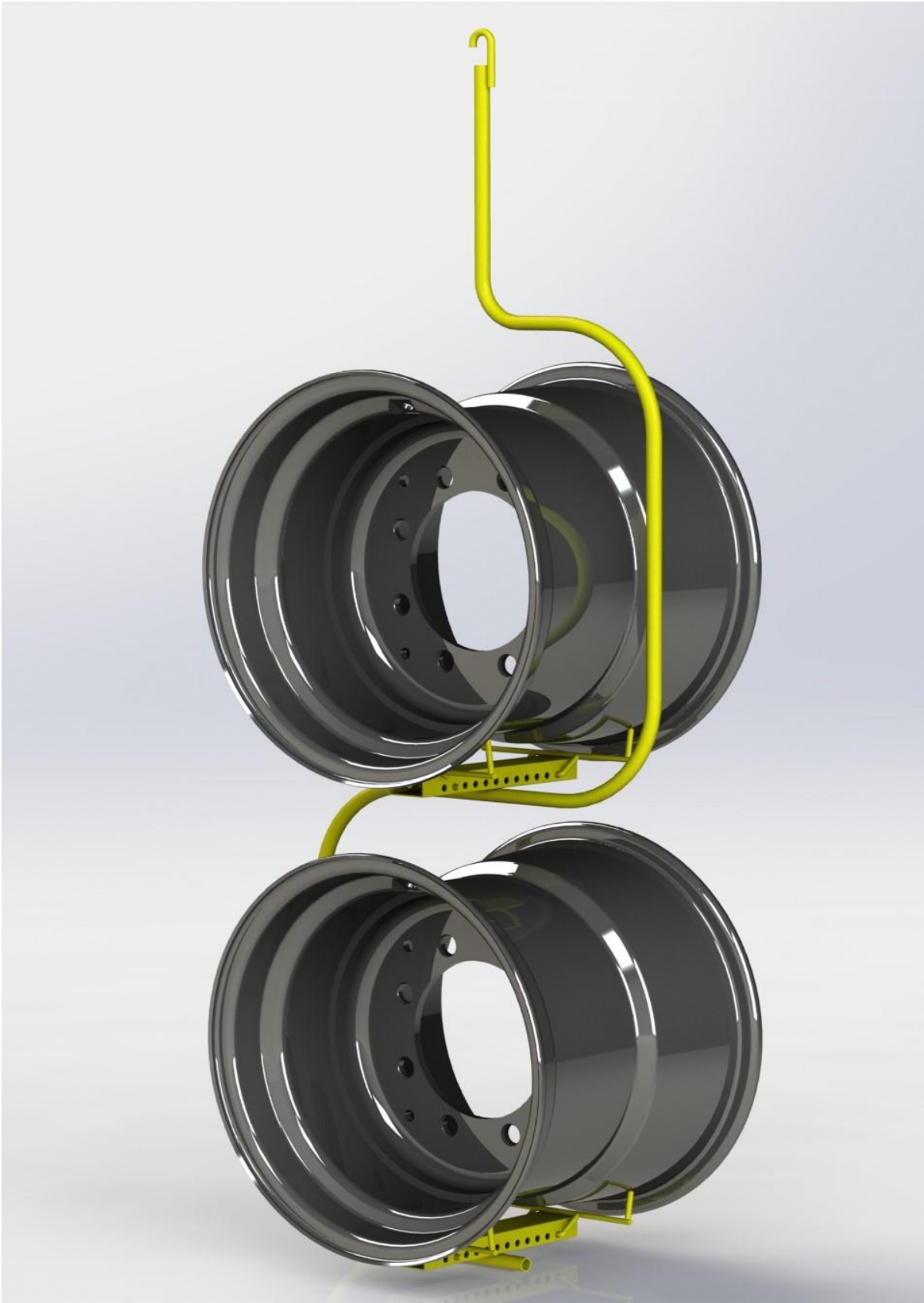

Figure 6: Example of two 20" wheels carried on one hanger

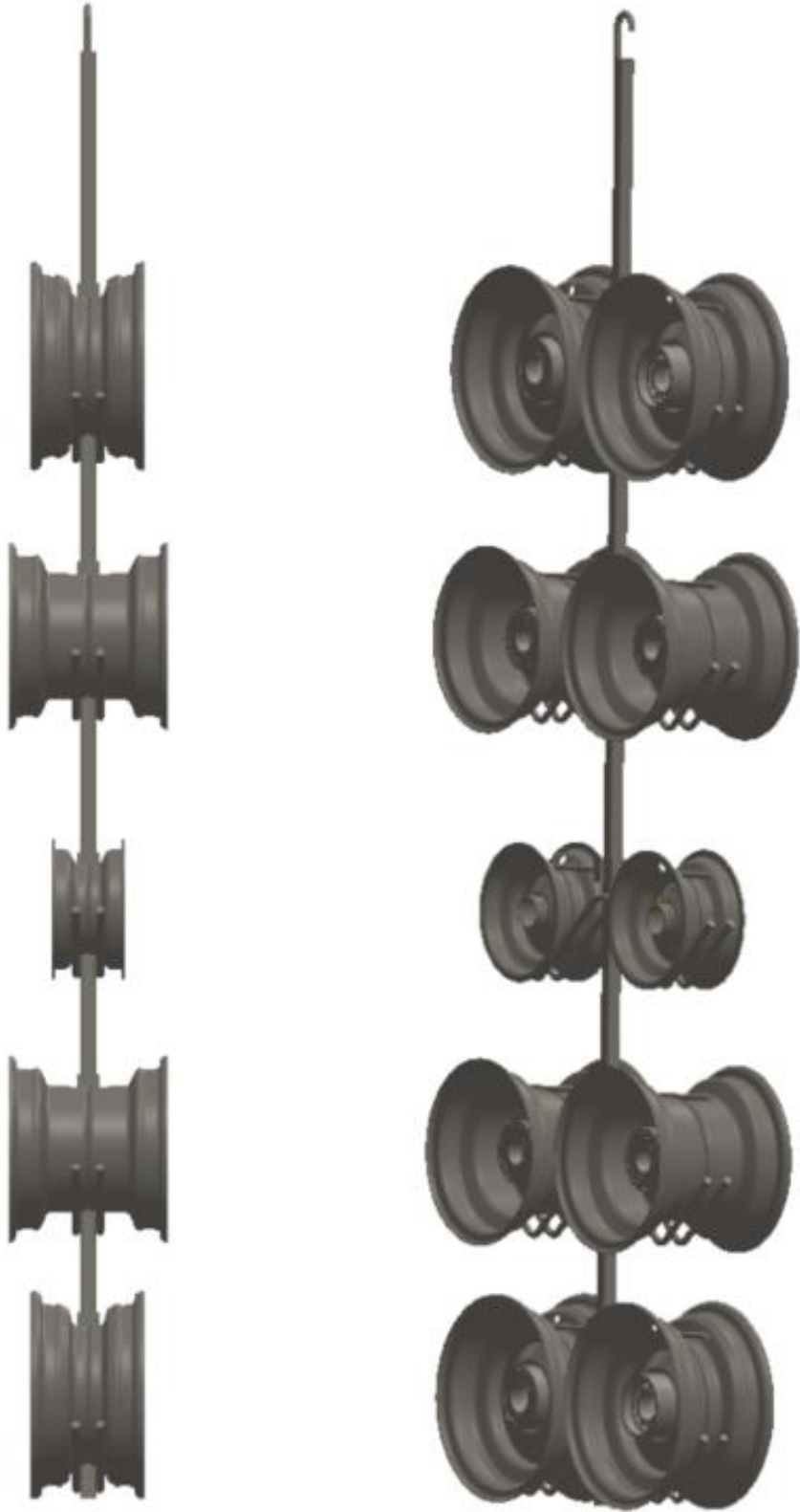

Figure 7: different diameter wheels carried by the same hanger (6" - 9")



## **2.4 Price terms**

The tender price should be expressed in the absolute amount in EUR and will remain unchanged during the duration of the Procurement Contract. All costs and discounts must be included in the tender price without value added tax.

Values can also be expressed in a currency other than EUR and in this case, when calculating the equivalent value, the Contracting Authority uses the average exchange rate of the Croatian National Bank for the currency, subject to conversion into EUR, valid on the date of sending this open tender invitation for publication.

## **3. DELIVERY TERMS**

### **3.1 Place of delivery**

Place of delivery will be the at the premises of the Project Promotor, Factory STARCO Beli Manastir d.o.o., Osječka 1a, 31300 Beli Manastir, Croatia.

### **3.2 Delivery terms**

The preferred term of delivery is DAP, according to Incoterms 2022.

The subject matter of procurement shall be delivered not later than 23.7.2023. Upon the delivery of the subject matter of procurement the Installation and Commissioning should be obtained within 2 weeks' time.

Partial deliveries are allowed, if the unit is delivered as a whole, meaning it can be installed and put into operation as such. Delivery of the unit without certain parts that make it functional are not permitted.

The subject matter of procurement must meet European standards.

The delivery terms expressed in the tender offer will be an important part in evaluation process of offers- detailed explanation is in the Section 5. TENDER SELECTION CRITERION.

## 4. TENDER DATA

### 4.1 Tender content

When preparing the offer, the tenderer must comply with the requirements and conditions of this tender. The tenderer may not change or add to the text of the call for tenders in a way that changes the form of the annexes signed by the legal representative. All costs of preparing the offer are at the expense of the tenderer.

The tender must contain at least:

- Name of the Tenderer, address and personal ID No. (OIB)
- Completed offer with technical specifications addressing the technical requirements mentioned in Section 2.3 Specifications
- Clearly indicated price and delivery terms

### 4.2 Language of the tender

The tender is submitted in Croatian or English, and in Latin script.

### 4.3 Tender submission

The complete tender must reach the Contracting Authority at the address of the contracting authority in a sealed envelope or via email address by the end of the tender period. Incomplete offers will be excluded from the evaluation.

The sealed envelope must indicate:

On the front:

STARCO Beli Manastir d.o.o.

Osječka 1a, 31300 Beli Manastir, Croatia

Procurement number 2023/364026 - P

Subject matter of procurement: WHEEL HANGERS TENDER – DO NOT OPEN

On the back:

Name and address of the tenderer, personal ID No. (OIB)

Email submission:

Must be sent to: [dejan.adler@starco.com](mailto:dejan.adler@starco.com)

SUBJECT: Procurement number 2023/364026 – P2

Subject matter of procurement: WHEEL HANGERS TENDER

#### **4.4 Deadline and method of tender submission**

The tender offer must be received by the Contracting Authority, in a sealed envelope, at the address of the Contracting Authority referred to in item 4.3 or via email address referred to in item 4.3 of this Open Tender Invitation, no later than 05/06/2023 at 15:00 Central European Time.

The tenderer independently determines the method of tender submission and bears the risk of possible loss or untimely tender submission.

Tenders received after the deadline for tender submission will not be subject to evaluation of tenders.

Opening of tenders is not public.

#### **5. TENDER SELECTION CRITERION**

The cheapest option that fulfils the requested specification, estimated value up to 10.000€.